

STEAM GENERATOR

WITH THE NEW OC-C KEYPAD

USER MANUAL



FOREWORD

Please take the time to read these instructions before you begin as they contain important information about the installation operation maintenance requirements.

OC-B Series steam generators are available in specifications from 6kw, 9kw, 13.5kw & 18kw and are equipped with our OC-C intelligent controller. With this not only you can control the temperature and time duration of the steam bath but also the light and fan of the steam room if installed, the automatic drain valve, automatic descaling, alter the working mode, as well as displaying the steam generator's status by means of the 8 LEDs on the panel. Please note also that one "OC-C" controller can control multiple OC-B Series steam generators.

Every OC-B Series steam generator is thoroughly tested before leaving the factory so there may be the remains of water inside the boiler.

IMPORTANT:

- ★ read the manual before installation and operation.
- ★ This appliance must be connected to an all pole isolator.
- ★ This equipment must be installed by competent person.
- ★ Disconnect the power supply before exposing electrical connections.
- ★ Confirm the right voltage to your steam generator 1 or 3 phase.

SAFETY PRECAUTIONS FOR STEAM BATHING:

- ★ Elderly persons, pregnant women, or these suffering heart disease, high blood pressure, diabetes or not in good health are advised to seek medical advice before using a steam room.
- ★ Do not smoke in the steam room.
- ★ Avoid using the steam room immediately after strenuous exercise.
- ★ Do not use the steam room when under the influence of alcohol.
- ★ Leave the steam room at once if you feel sleepy, sick or uncomfortable.
- ★ Ensure good ventilation through the steam room – 10cubic meters per bather per hour recommended.
- ★ We do not recommend this product is used by children under the age of 16 years.
- ★ Commercial operators should post a notice of these precautions in a prominent position.

INDEX:

Chapter 1: Specification	Page: 3
Chapter 2: The frame and functions of the OC-B series steam generator	Page: 5
Chapter 3: Installation	Page: 8
Chapter 4: Testing and Operation	Page: 13
Chapter 5: Troubleshoot guide	Page: 19
Chapter 6: Maintenance	Page: 21

Chapter 1: Specification

Available Models:

Model	Power(KW)	Voltage (V)	Phase(N~)	Current(A)	Dimensions(mm) (L×W×H)
OC-90B	6.0	230/400	1/3	26.4/13	530×210×370
OC-90B	9.0	230/400	1/3	39/13	530×210×370
OC-135B	13.5	230/400	1/3	56.0/19.5	530×230×460
OC-180B	18.0	230/400	1/3	78.0/26.1	530×230×460

Remarks if greater more power is required, one OC-C controller may be used to control two or more steam generators, e.g. if you need a 30KW steam generator you can use one OC-C controller to control two 15kw steam generator or three 10 kw steam generators .

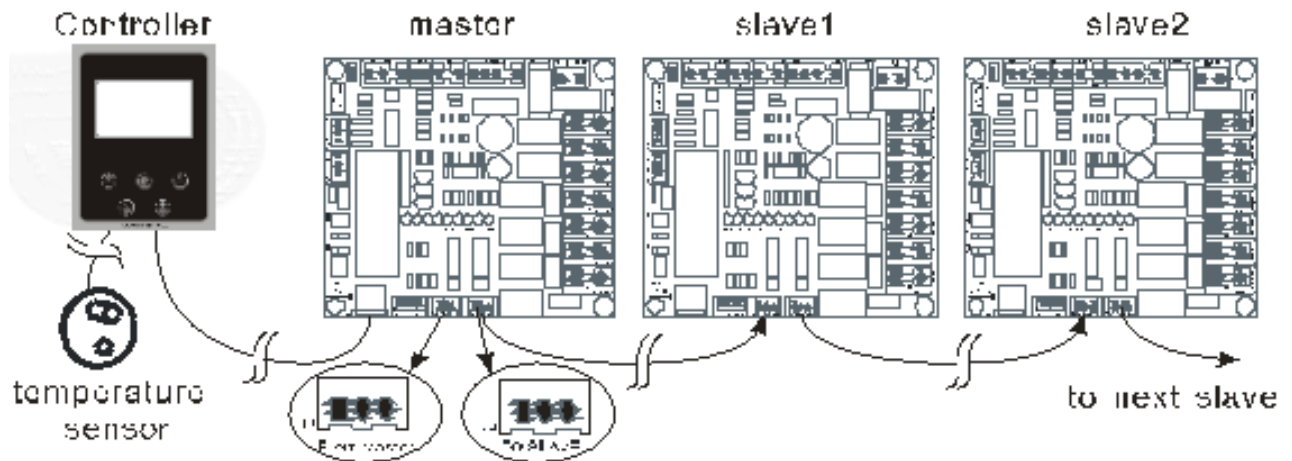
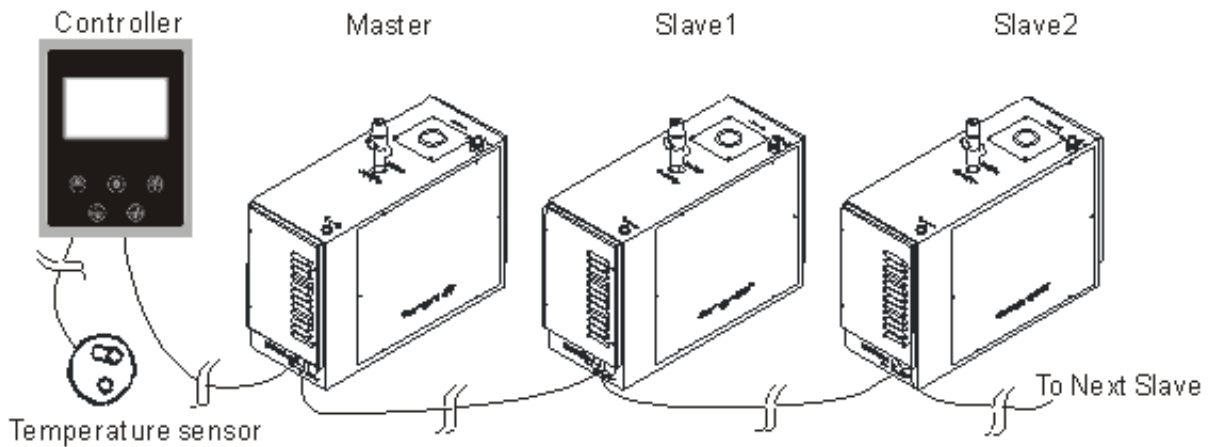

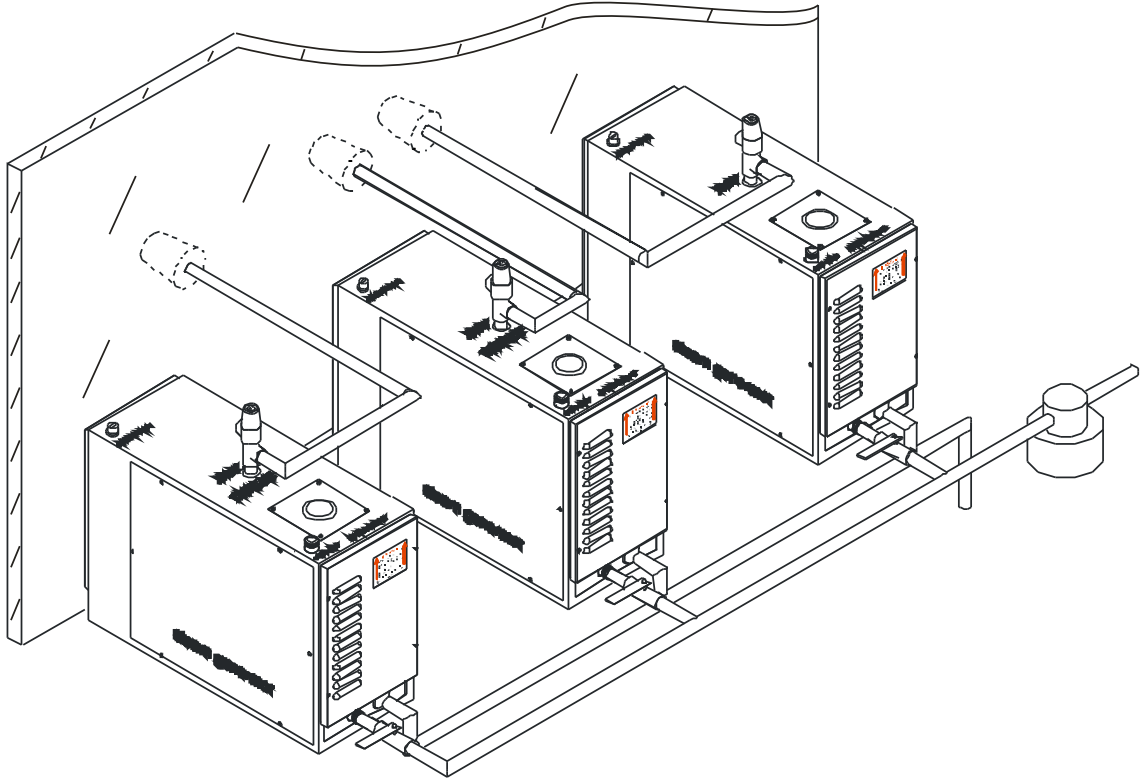

1. Parameters and dimensions of OC-C and OC-S controller: (chart 2)

model	working time (minutes)	Temperature	Dimension(mm) (LxWxH)	remarks
OC-C	10-240	30-60°C 86-140°F	155x113x19	When the time widow displays “NO” the generator will operate continuously until it is switched off.
OC-S	30		60x60	Steam on demand switch, press once it will work 30 minutes , press again ,it stop works , special for commercial user

Chapter 2: The frame and functions of the OC-B series steam generator

Parts description of the steam generator:

1. The frame of steam generator (Figure 4)

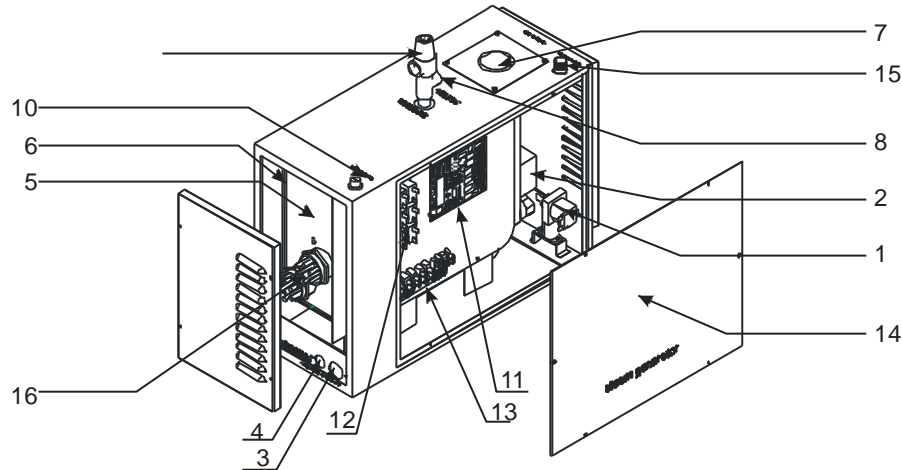

Figure 4

(2) Parts instruction (chart 3):





No.	Part	Description
1	Water inlet valve.	Automatically controls the water flow (maximum pressure 2bar).
2	Drain valve.	Controlled by controller .turn on or turn off to drain water.
3	Power entry.	The route of power wire.
4	Control cable entry.	The route of control cable.
5	Stainless steel tank.	Boiler.
6	Insulation material.	Reduce the loss of the boiler heat.
7	Water lever probe.	Detect the water level.
8	Steam outlet.	Steam outlet.
9	Pressure relief valve.	Operates if the pressure in the boiler exceeds 0.12MPa.
10	Overheat switch.	Boil dry protector operates at 110 °C.
11	Main circuit board.	Control center.
12	Accessorial circuit board.	Connect and control the heat element.
13	Terminal.	Connection for power supply.
14	Earth wire plug.	Connection for earth wire.
15	Descaling liquid inlet.	Descaling liquid inlet (1/2 inch).
16	Heat element.	Heat element.















OC controller operation instruction

1. Indication for the screen:(Fig 1)



Fig 1

Part	description
	Dual function button, push to power on the unit or to move right when selecting menu item.
	Dual function button push to operate the light or to move left when selecting menu item.
	Dual function button push to drain the generator manually when not steaming or as Increase button when adjusting time or temperature when in menu item.
	Dual function button switches a fan on and off and is also used as decrease button when adjusting time or temperature when in menu item.
	Press to enter menu and to select menu item

	Instruction			Instruction
	Clock time			Drain symbol (displays when draining)
	Heating symbol (display when temp lower than setting temp is detected)			Lack water symbol (display when lack of water or when tank is filling.)
	Temp Display			High temp symbol (when boiler overheats)
	Mode Indicator: A, B and AUTO mode			fan (displays when fan is running)
	Temp symbol (Celsius or Fahrenheit)			lamp (displays when lamp is on)
	Temp keeping symbol (display when set temp is reached)			Key lock symbol (displays when key-button was locked, then the setting is null, can only on/off steam generator, lamp and fan)
	Descaling symbol (display when descaling, flashes when descale is in progress.)			Timing symbol (display when you set the steam generator to be turned on a certain time, only works under auto mode)

Please note, for the generator to operate in steam on demand (B) mode the steam on demand button must be connected.

2. OC-S Steam on demand switch

The steam on demand switch can be located inside or outside of the steam room.

When the switch is pressed, the LED indicator inside the switch engages red and steam will be generated for 30 minutes. At the end of 30 minutes or if the switch is pressed again, the light will go out and the steam will stop.

3. Commercial mode instruction (OC-C+OC-S)

If OC-C is under domestic mode then the unit can only be controlled by the OC-C controller and not by the OC-S controller.

When OC-C is set to B mode, then the steam generator status will change to waiting status (the time window will show B in the top left corner), then press OC-S it will operate steam generator.

Every press will set the steam generator to work for 30 minutes. The temperature control will rely on the OC-C controller's setting before it was set to commercial mode.

Chapter 3: Installation

- ★ Isolate the power supply before installation.
- ★ Confirm the model you have selected is suitable for your steam room, please refer to chart 5.
- ★ Mount the steam inlet nozzle approximately 150mm up from the floor and it should be at least 200mm from the seating.
- ★ If the steam generator is installed in an inaccessible place ensure that both the electrical power and water supply can be isolated in an emergency.
- ★ The minimum water inlet pressure is 0.25bar and the maximum is 8bar, we advise that the water pressure not exceed 5bar
- ★ The steam pipe from steam generator to steam room should be kept to a minimum, pipes longer than 5 meters should be insulated to prevent heat loss. Steam pipes will be hot during use and must be protected against accidental contact.
- ★ Keep the number of right angle bends to a minimum and ensure that in the run of the pipe, one does not create a trap into which condensation can gather and cause a blockage. I.e. the pipe must not go down and then up.
- ★ There must be no valve or other blockages/gate devices in the steam pipe.
- ★ The steam pipe should be copper or of other material which can endure 150° C temperature, copper.
- ★ The Steam generator should be level side to side and front to back and should be installed so that the arrows on the case point up.
- ★ Do not install the steam generator in close proximity to hazardous substances.

The following table should be referred to for guidance only. Please note that the size of heater required to heat a particular size of steam room will vary according to a number of factors including the type of material used for construction, the height of the steam room and the ambient temperature.

For lightweight materials such as plastics and laminates 1 KW will heat up to 1 cubic meter of air. For dense materials such as stones and ceramics which will conduct the heat away more rapidly allow for up to 2KW per cubic meter of air. Hot air rises so restricting the height to around 2 meters will ensure the user is sitting in the steam for higher ceilings you may need to increase the power requirement.

The following table is given as a guide, ambient air temperatures and frequency of use (number of door openings) can also affect the power requirements.

Model		Steam room volume (m3)
OC-60B	6KW	4 -7
OC-90B	9KW	7 - 10
OC-120B	13.5KW	10-15
OC-180B	18KW	15-20

Installation:

The steam generator should be installed in dry well ventilated place in close proximity to the steam room. It can be placed on the floor or hung on the wall.

In order for installing and maintenance, please refer to Figure-6B to ensure that you have prepared enough space. To hang the generator on a wall drill 3 holes 8mm in diameter in accordance with the table below and use the wall plugs and screws provided. Fix the top 2 screws in place first then hang the generator by the 2 keyhole shaped holes in the back plate. Then with the front cover removed fix the 3rd screw to secure the unit in place. Refer to Figure 6A.

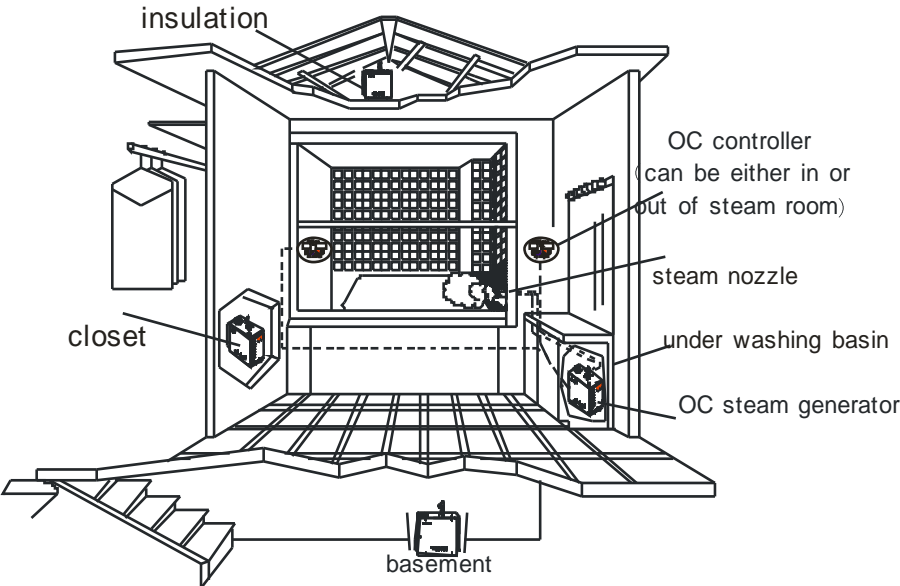

fig 6

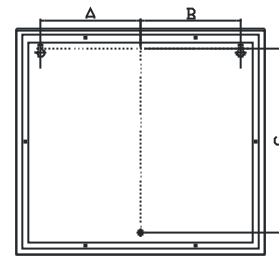

Figure 6A

Model	A	B	C
OCB-09B	215	215	315
OC135B, C180B	215	215	405

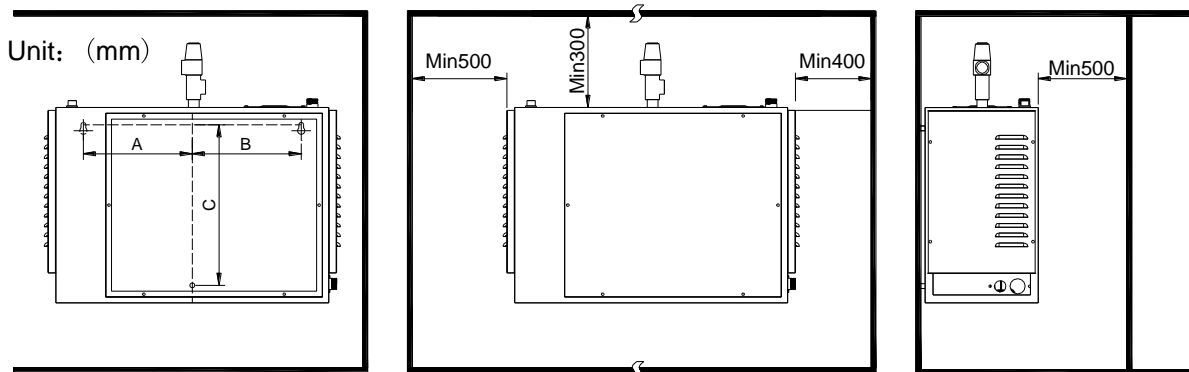
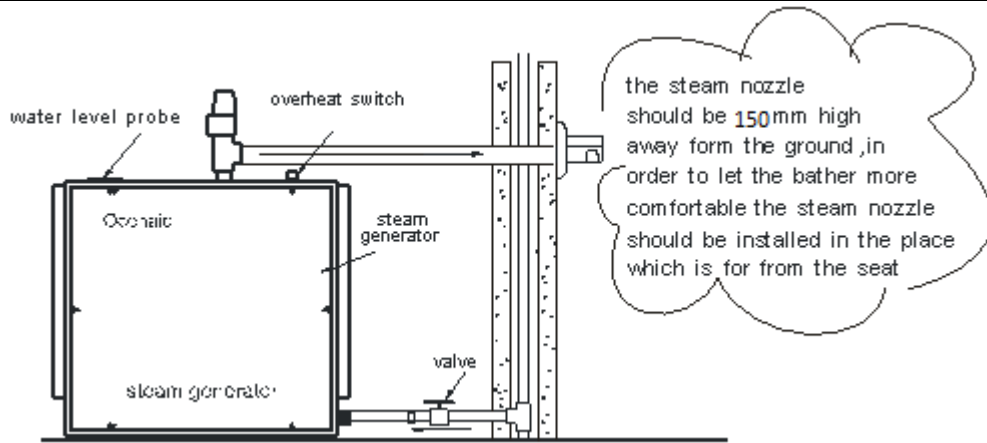

Figure 6B

Water and steam connection:

1. The water supply pipe and steam pipe should comply with local standards.
2. Connect the water inlet valve of the generator to the 15mm mains water supply using a flexible hose with 1/2 inch fittings.
3. Steam outlet (1/2 inch or 3/4 inch) use the same dimension copper pipe to connect it, if the steam pipe is longer than 5 meter it should be insulated. During use the steam pipe will be very hot and must be protected against accidental contact. Note that according to the location it may be necessary to attach an additional length of pipe to the pressure relief valve in order to divert the steam flow to a safe direction should the valve operate.



4. Connect the drain outlet to a suitable drain via a grey hose or copper pipe with the appropriate fittings.
5. Make a secure connection between steam nozzle & steam pipe.
6. Use non corrosive hose with ½ inch unions to connect between the descaling liquid container and the inlet valve. Note that the descaling liquid container must be mounted at least 500 mm above the steam generator.

Installation for controller and temperature probe:

OC-C controller is water proof and can be installed inside or outside the steam room.

1. Ideally the control panel should be installed at a height of approximately 1500mm for ease of use.

Installation method: Insert a conduit round box into the wall at approximately 1500mm.

Pin one end of the controller cable (6 core) to the circuit board ports in steam generator and connect the other end to the controller's cable.

Open the front cover of the OC-C Controller. Put the protuberant back of the controller inside the round box on the wall , then fix it to the wall replace the cover.

2. Temperature probe installation:

The temperature probe is installed inside the steam room between 1.2 to 1.5 meters high and away from the door. Use silicone to fix it to the sensor cover and connect to the wire from the controller (2Pin), then fix the sensor cover in place with silicone.

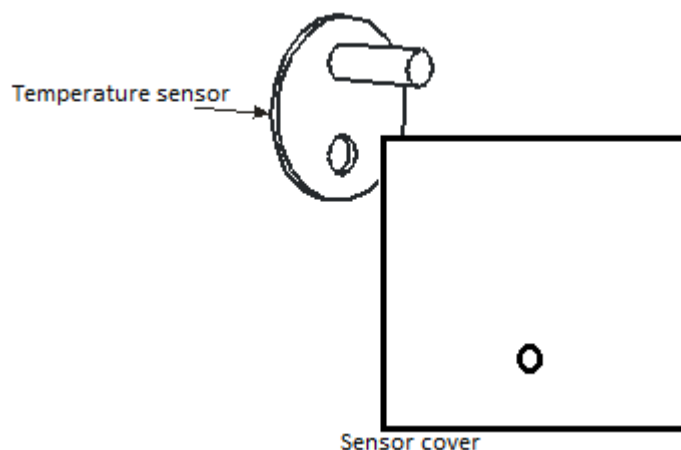

Installation for power supply and control cable:

Confirm the correct voltage of power supply and wires.

Remove the knock out for the power cable entry and use a rubber grommet to protect the cable. Connect the conductors to the correct terminals. For a single phase power supply use the copper bridge connectors, for 3 phase supply remove them.

Ensure the power supply wire and control cables remain separated to prevent magnetic field of power supply wire from disturbing control cable signal.

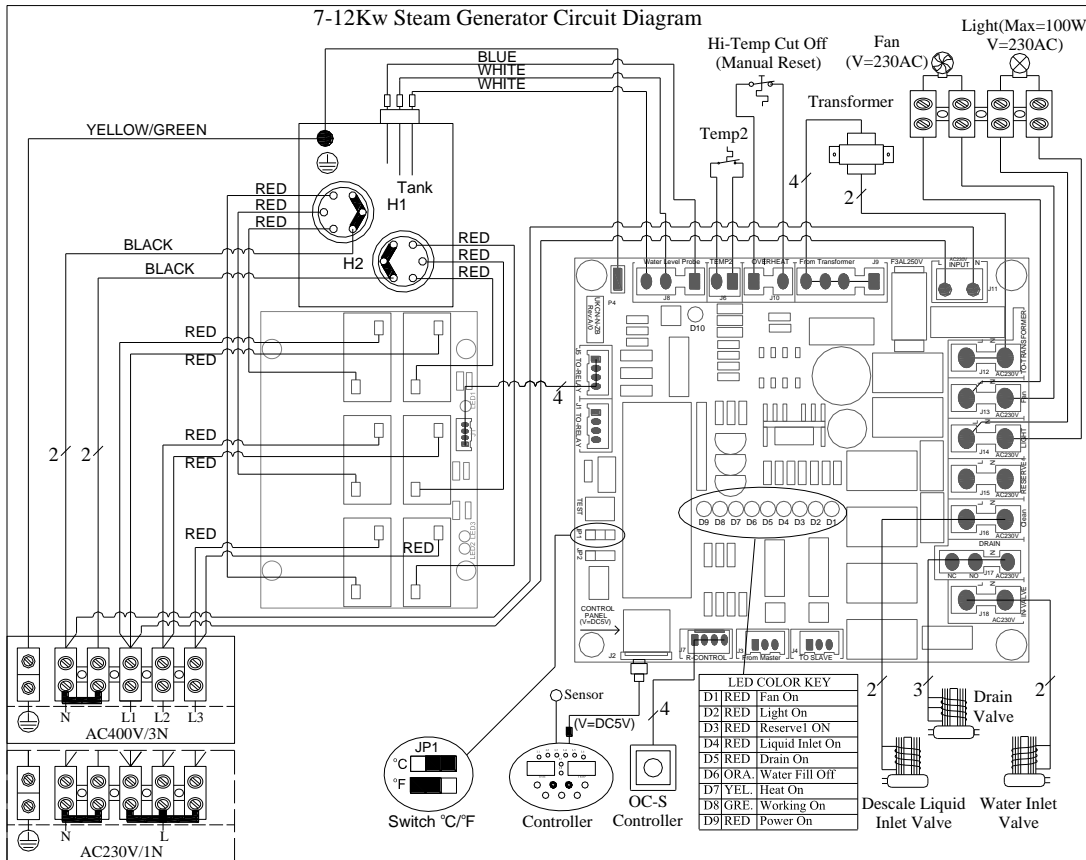

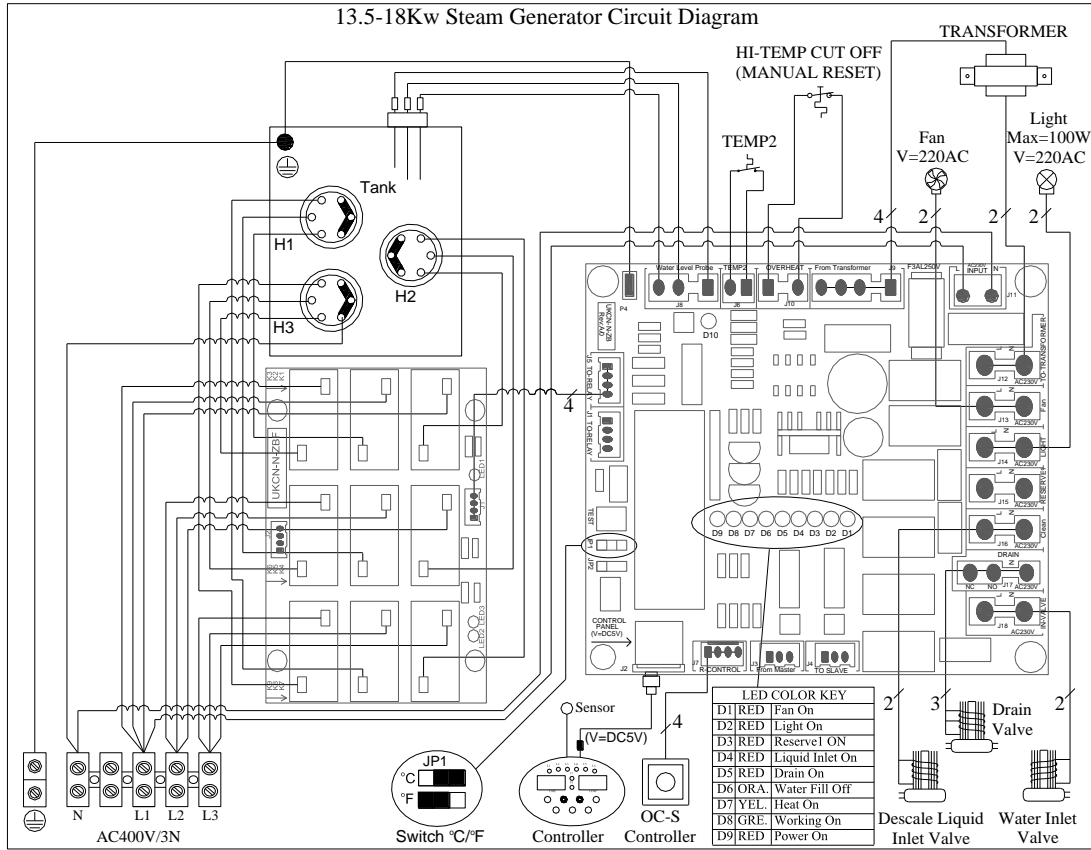

Steam on Demand Function:

Commercial operators may wish to take advantage of the steam on demand function which will allow customers to press the steam on demand button located inside the steam room after which the generator will operate for 30 minutes then stop until activated again.

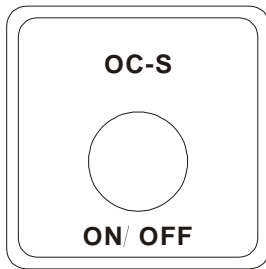



To operate the steam on demand function install the controller inside the plant room alongside the generator then fit the push button supplied in a convenient location inside the steam room and connect to the controller with the cable provided.

Chapter 4: Testing and Operation

Once the installation has been completed and checked turn on power and water supplies and carry out the following test.

1. Setting The Temperature

When the controller is on, press the  button, press  or  to select the function setting in Fig 2 status.

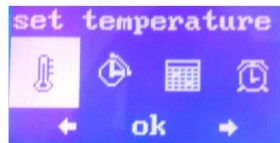







Fig 2



Fig 3

1. Press  to enter Fig 3 status, press  or  to adjust the temp (35°C~60°C or 95 ~ 140 °F), press and hold the  or  for faster increments.
2. Press the  button to confirm the setting, otherwise it will exit after 20 seconds and the temp setting won't be saved.

2. Setting The Working Time

1. When the steam generator is on, press the  button, press  or  to select the function setting in fig 4.

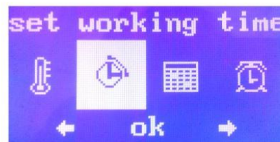

Fig 4

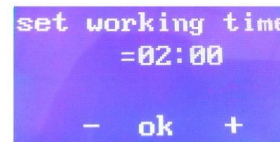











Fig 5

2. press  button enter Fig 5 status, press  or  to adjust the time(15 minutes to 4 hours ,longer than 4 hours will display “NO” which means that the working timer has been disabled and the generator will continue to work until it is manually turned off.), press and hold the  or

 for faster increments.

- press  button to confirm the setting ,otherwise it will exit after 20 seconds and the time setting won't be confirmed

4. Setting The Working Mode

- Press  button and press  or  to select function setting in Fig 6.

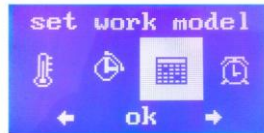

Fig 6

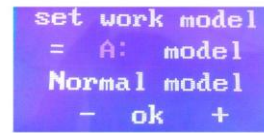





Fig 7

- Press  button enter Fig 7 status, press  or  choose model (A 、 B 、 AUTO),
- Press  button to confirm the setting, otherwise it will exit after 20 seconds and the mode setting won't be saved.

5. Setting The Timer Function To Turn The Generator on or Off.

- Press  button, press  or  select function setting in Fig 8



Fig 8

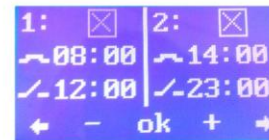



Fig 9

- Press  enter Fig 9 status and press  or  to choose the functions you want to set

when the symbol is flashing press the  or  to select setting.

- Instruction for the timer function

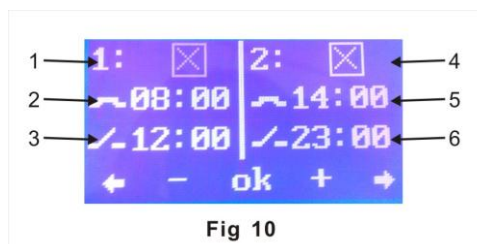



Fig 10





No.	instruction	No.	instruction
1	timer1(“√”means enabled, ”X” means turn off)	4	Timer 2(“√”means enabled, ”X” means turn off)
2	Timer 1,turn on time (00: 00~12: 40)	5	Timer 2 ,turn on time (12: 00~23: 40)
3	Timer 1turn off time (00: 15~12: 55)	6	Timer 2 turn off time (12: 15~23: 55)

3. Press  button to confirm the setting ,otherwise it will exit after 20 seconds and the mode setting won't be saved.

6. Using The Descaling Function

1. Press  button and press  or  select function setting in Fig 11.



2. Press  button to enter FIG 12 status, press  or  choose the functions you want to set, when the desired symbol is flashing, press the  or  to set.

3. Descaling instruction Fig 13









No.	instruction
1	Descaling(“√”means enabled,“X”means turn disabled)
2	Descaling start time from (00: 00~23: 00)
3	Descaling end time from (00: 00~23: 00)

4. Press  button to confirm the setting ,otherwise it will exit after 20 seconds and the setting won't be saved.

7. Setting The Clock Time

1. Press  button and press  or  select function setting in Fig 14





2. Press  button enter Fig 15 status, press  or  to adjust time , press and hold the  or  for faster increments. Use the  or  to select Hours or Minutes.

3. Press  button to confirm the setting, otherwise it will exit after 20 seconds and the setting won't be saved.



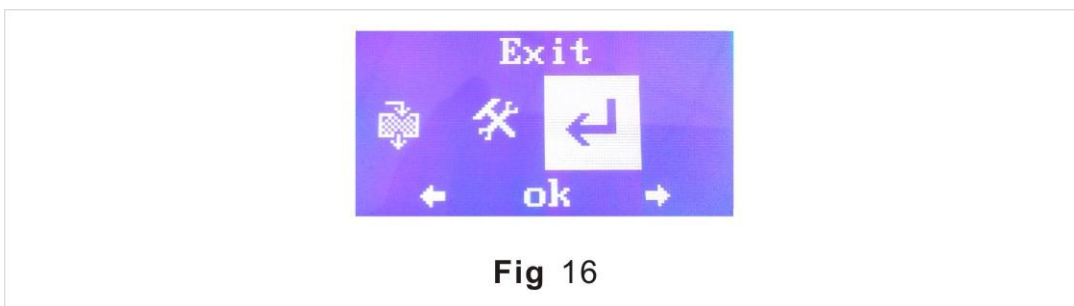







8. Exiting The Settings Menu

1. Press  button and press  or  enter Fig 16 status





2. Press  exit setting or wait 20 seconds to exit automatically.

General Operation

2. On the control panel press the “  ” key, (the key has a time-lapse function, press it for 1 second), the time and temp windows will display and the generator is now on.
3. The water inlet valve turns on & water enters the boiler, the  symbol is now displayed on the controller screen. When the water level rises to the low water sensor level the elements switch on and the heating symbol  is displayed, several seconds later when the high water sensor is reached the water inlet indicator  is no longer displayed and the water inlet valve will turn off.
4. After a few minutes of operation it will begin steaming, for small steam generator 2-3 minutes, for larger generators 3-5 minutes.
5. Press the “  ” key again the controller turns off, there will be no data on display and the generator will stop - no more steam.
6. Press the “  ” key once more (temp and time display again) after a few seconds the generator will begin steaming again, let the generator operate for a short while - the water level will fall to the low water level, check that the water inlet valve opens automatically (the water inlet indicator  is displayed on the controller screen) While the cold water enters the boiler, the steam generator still produces steam. Once the high water level is reached again the water inlet valve will close the and the water inlet indicator  is no longer displayed.
8. If the steam generator has operated for 10 minutes or more, when it is turned off (manually or automatically) it will enter the automatic drain down cycle. This means that once the temperature of the water in the boiler falls below 80 °C it will drain and then flush before it can start steaming again.
Note: when the steam generator is off you can drain it manually (flush boiler and drain) by pressing the  button – the drain symbol  will then be displayed on the controller screen - note that the water will only start draining once the temperature has fallen below 80 °C.
9. When the preset temperature for the steam room is reached 2 of the 3 element banks will switch off allowing just the 1 bank to continue heating to maintain the temperature. Elements will cycle on and off to maintain the temperature to within approximately 2.5 degrees above or below the preset requirement.
11. Boil dry protection – if the water supply fails the water level symbol  will be displayed and the steam generator will stop until the water supply is restored.

12. The light function can be turned on by pressing the  button and can output 230V AC to power the transformer for a 12V steam room lamp.
15. To change the display temperature from Celsius (default) to Fahrenheit, alter the settings of the JP1 pins on the circuit board, please refer to chapter 3 for circuit diagram.

Chapter 5: Troubleshoot guide

<p>When the generator is turned on there is no display on control panel.</p>	<ol style="list-style-type: none"> 1. Power supply. 2. Transformer. 3. Main circuit board. 4. Controller. 5. Control cable or port. 	<ol style="list-style-type: none"> 1. Check power supply voltage. 2. If the indicator LED which indicates power supply to the circuit board isn't on in red then check transformer. 3. If the LED is red then remove the controller and use the circuit board to turn on the steam generator. If the steam generator still doesn't work then the circuit board is faulty and must be replaced. 4. If turning the unit on via the circuit board works, then the controller or controller cable could be faulty.
<p>When the controller is on, however the heating symbol does not display and no steam is produced.</p>	<ol style="list-style-type: none"> 1. Water supply valve is closed. 2. Water inlet magnetic valve. 3. Water level probe. 4. Main board. 5. Earth wire of boiler and circuit board. 6. Circuit board 7. Heat element. 	<ol style="list-style-type: none"> 1. If the symbol  for water level is displayed, then check the water supply and water inlet valve. 2. Check the connection of the water level probe. 3. Check earth wire connection of circuit board and boiler. 4. If the symbol  for water level is not displayed then check circuit board. 5. Check if overheat switch is disconnect. 6. Check heater elements.

Steam generator is turned on, control panel is normal and the indicator symbol for heating is on but there is no steam.	<ol style="list-style-type: none"> 1. Main circuit board. 2. Relay circuit board. 3. Heat elements. 	<ol style="list-style-type: none"> 1. Replace main circuit board. 2. Replace relay circuit board. 3. Replace heater elements.
Temperature window displays "LC".	<ol style="list-style-type: none"> 1. Water level probe Connection. 	<ol style="list-style-type: none"> 1. Check connection or change temperature probe.
Temperature window displays "HC".	<ol style="list-style-type: none"> 1. Water level probe or sensor is short circuiting. 	<ol style="list-style-type: none"> 1. Check water level probe connection. 2. Check the controller for short circuits. 3. Check sensor wire for short circuits.
When the steam generator is switched off, water starts to flow out of the steam nozzle.	<ol style="list-style-type: none"> 1. Water inlet valve. 	<ol style="list-style-type: none"> 1. The water inlet valve may require cleaning or replacing.
When the main power supply is turned off, water starts to flow out of the steam nozzle.	<ol style="list-style-type: none"> 1. Water inlet valve. 2. Circuit board. 	<ol style="list-style-type: none"> 1. Replace circuit board or water inlet valve
Steam generator does not cut off after it has been switched off.	<ol style="list-style-type: none"> 1. Circuit board. 2. Controller. 3. Relays on accessorial circuit board. 4. Water level probe. 	<ol style="list-style-type: none"> 1. Cut power supply and contact your local dealer.

Please note that we recommend all repairs to be carried out by a suitable qualified person.

Chapter 6: Maintenance

The most common cause of problems with steam generation is the build up of scale resulting from dissolved solids within the water. Scaling can cause the elements to fail, the water level sensors not to function and premature failure of the O rings resulting in leaks from around the elements. The extent of the problem will vary according to the degree of hardness in the local water supply.

For all commercial operators we recommend the use of a water softener.

All users commercial and domestic must ensure a regular maintenance routine to descale the generator, the frequency of which will vary according to the degree of hardness in the local water supply and the amount of time the generator is used for. Check the water for hardness and arrange the descaling routine accordingly.

- High levels of hardness descale once every 50 to 100 hours of operation
- Medium levels of hardness descale once every 100 to 250 hours operation
- Low levels of hardness descale once every 250 to 1000 hours of operation.
-

To descale the generator use a solution of weak acid crystals (such as citric acid) mixed with water.

Citric acid crystals are available in sachets for descaling from Continental (Pty) Ltd.

Commercial operators in hard water areas may wish to purchase larger quantities. Follow the instruction supplied with the crystals and allow sufficient time for the solution to dissolve the scale before flushing out the generator.

Faults arising from a result of failure to descale the generator are not covered under warranty.

Because heating and cooling cause expansion and contraction it is important to inspect all the water and steam inlets and outlets as well as their pipes and connectors on a regular basis to ensure there are no leaks.

Clean the filter net in the magnetic valve according to the water quality in the location.

Your steam generator has been supplied along with a Water Scale Inhibitor. This will condition the water as it is supplied to the unit. Please note that this is not a replacement for the above de-scaling procedure (Commercial users). The Water Scale Inhibitor has a Cartridge which must be replaced regularly. Please see below:

Home user: Every 2 years or 600 hours whichever comes first.

Commercial user: After 600 Hours of use, approximately every 3 months.

The condition of the wiring and electrical integrity of the generator should be checked regularly - for commercial operators this should be at least once a year.

Guarantee:

All generators are guaranteed for 12 months from the date of purchase. This guarantee excludes consumable items such as the electrical elements and failures resulting from misuse or abuse such as a failure to descale as above.

Unit Serial Number:	
JC Number:	
Installation Date:	
Customer service:	Customerservice@continentalsa.co Tel: +2711 822 7170 Fax: +2786 764 0450